

Voyager 2 Slim Mobility System



SPECIFICATIONS

CTG-16864-KLAS-V2S Voyager 2 Slim Mobility System

Cases2Go's CTG-16864-KLAS-V2S injection molded plastic case integrates the KLAS Voyager 2 Slim chassis into a compact, airline carry-on compliant case with fully integrated power distribution, high-airflow fan panel, and optional modules. Case is engineered to exceed ATA Spec 300, Category 1 and MIL-STD-810H.

BASELINE FEATURES

- Rugged injection molded case from SKB
- Quiet-glide wheels with retractable pull handle
- Pressure relief valve
- Black stainless-steel hardware - RoHS / REACH
- Top surface for laptop or optional sleds
- Integrated IEC 320 switched power input
- KLAS Voyager 2 Slim Standard Chassis
- Two KLAS Voyager 15VDC 90W PSU's
- 212 CFM High Airflow fan panel
- Quick access to KLAS V1's (sold separately)
- Outside dimensions 21.75 x 13.88 x 9
- Weight: 28 lbs. (Baseline system)



OPTIONAL CONFIGURATIONS

- KLAS Voyager 1 Plus Battery packs
- KLAS Cradlepoint Sled
- KLAS HAIPE / KG250 Sled
- StarLink Mini + (1) KLAS Sled



Authorized Reseller of KLAS Products

CASES2GO is a Tampa-based Value-Added Reseller (VAR) with over 40 years of military packaging and contracting experience, supporting USSOCOM for 24 years. We are a Small Business, committed to providing our military and government customers with deployable case solutions that are battle tested and field proven.

www.cases2go.com
sales@cases2go.com
813-513-9911

When it's **MISSION CRITICAL**, the **CASE** makes the **MISSION POSSIBLE**

Voyager 2 Slim Mobility System

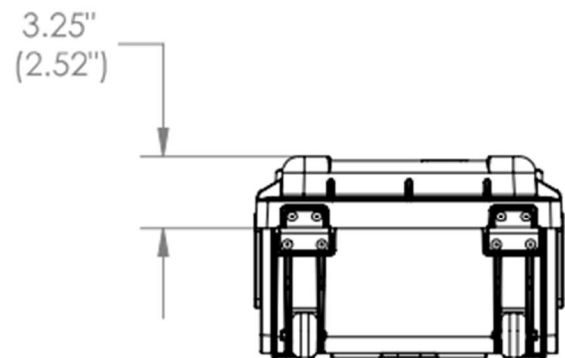
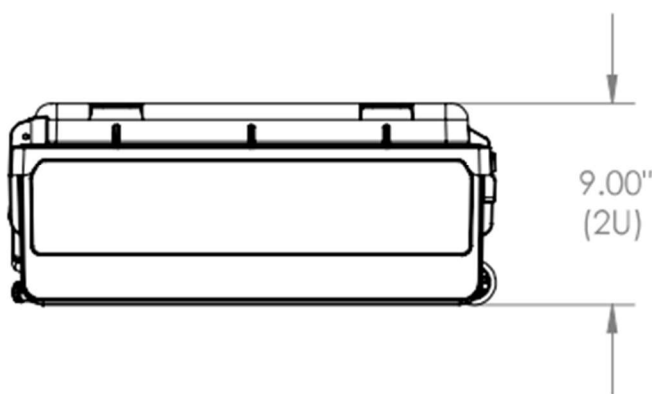
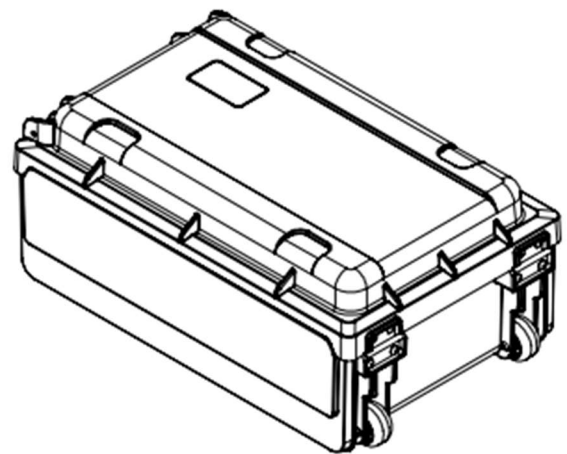
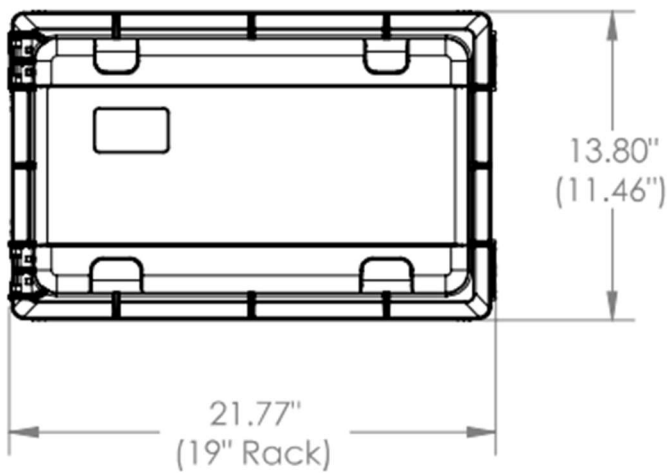

CASES2GO is a Tampa-based Value-Added Reseller (VAR) with over 40 years of military packaging and contracting experience, supporting USSOCOM for 24 years. We are a Small Business, committed to providing our military and government customers with deployable case solutions that are battle tested and field proven.

www.cases2go.com
sales@cases2go.com
813-513-9911

When it's **MISSION CRITICAL**, the **CASE** makes the **MISSION POSSIBLE**

Voyager 2 Slim Mobility System



VOYAGER/2 Slim

Voyager 2 Slim is a two slot, rugged backplane chassis supporting two Voyager modules in a backpack or briefcase form factor.

Battery-backed power is provided by Voyager 1 and the system is also ideal for vehicle installs with addition of Voyager Module Battery Bracket (VMBB) or Voyager Module Adapter (KVMA).



VOYAGER/1+

Voyager 1+ is a rugged battery pack for use with the Voyager range of modules.

As an alternative to a backplane chassis, you can attach the Voyager 1+ battery pack to the rear of any Voyager module. The Voyager 1+ is especially suited to the higher power requirements of newer modules, such as the VoyagerVM 3.0, VoyagerVM 4.0, and VoyagerESR 2.0.

In addition, a battery-backed DC output is provided to power encryption devices, including ViaSat KG-250X, ViaSat KG-250XS, TACLANE-Nano KG-175N, KG-175D and Mini-Catapan.



CASES2GO is a Tampa-based Value-Added Reseller (VAR) with over 40 years of military packaging and contracting experience, supporting USSOCOM for 24 years. We are a Small Business, committed to providing our military and government customers with deployable case solutions that are battle tested and field proven.

www.cases2go.com
sales@cases2go.com
813-513-9911

When it's **MISSION CRITICAL**, the **CASE** makes the **MISSION POSSIBLE**

Voyager 2 Slim Mobility System



VOYAGER/HAIPE

VoyagerHAIPE Brackets provide easy mounting for HAIPE encryption devices to any Voyager network module with a Voyager 1 Chassis attached. The VoyagerHAIPE bracket secures the encryption device to the Voyager network module. The entire secure network enclave can then easily slide into a Voyager chassis such as Voyager 8 , Voyager 8+ and Voyager 2.

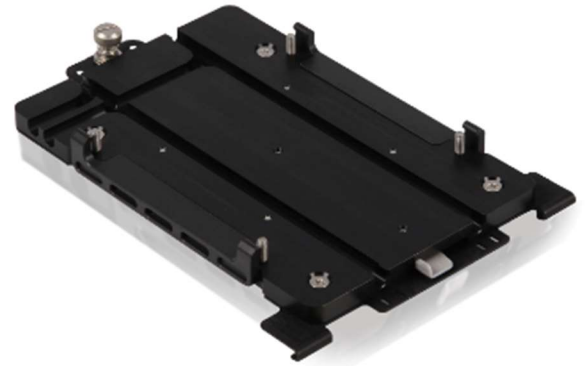

CASES2GO is a Tampa-based Value-Added Reseller (VAR) with over 40 years of military packaging and contracting experience, supporting USSOCOM for 24 years. We are a Small Business, committed to providing our military and government customers with deployable case solutions that are battle tested and field proven.

www.cases2go.com
sales@cases2go.com
813-513-9911

When it's **MISSION CRITICAL**, the **CASE** makes the **MISSION POSSIBLE**